



USE THE RIGHT TOOL FOR THE RIGHT JOB

What can you do to make your dealership stand out from the competition down the street? What can you do to make customers choose your place of business over another? **Providing quality service!**

"Use the right tool for the right job." We've all heard the phrase and it's true.

S&S® specialty tools are designed to make sure that you perform the job in a timely fashion and get it right the first time! Designed and built here in the USA for consistent operation and long life.

Specialty service tools increase a technician's efficiency and profitability. These tools will permit you to accomplish procedures that couldn't be done without the tool, allowing you to complete service procedures faster and safely. Your customers will know that the job is done right the first time.

Your investment in tools will pay for itself over and over and keep your customers coming back for quality service.

| | |
|--------------------------------------|------|
| Flywheel Tools | 9-2 |
| Flywheel Balancing Kits | 9-2 |
| Connecting Rod Checking Pins | 9-5 |
| Compression Release Socket Kit | 9-5 |
| Inner Primary Bearing Race Installer | 9-4 |
| Main Jet Tool | 9-5 |
| Rocker Cover Wrench Set | 9-5 |
| Top Dead Center Tool | 9-5 |
| Shop Supplies | 9-10 |
| Carburetor Jet Kits | 9-10 |
| Champion® Spark Plugs | 9-9 |
| Engine Stands | 9-12 |
| Oil Filters | 9-9 |
| Touch Up Paint, Lubricant, Sealants | 9-12 |
| Sprocket shaft Tools | 9-3 |
| Top End Tools | 9-5 |
| Anti-Rotation Bracket | 9-8 |
| Boring Plate Kits | 9-5 |
| Crankcase Oil Passage Drilling Jig | 9-8 |
| Crankpin Nut Clearancing Gauges | 9-8 |
| Cylinder Torque Plate Kits | 9-6 |
| Degree Wheel Kit | 9-7 |
| X-Wedge Tools | 9-4 |
| Bearing Protector Tools | 9-4 |
| Cam Alignment Tools | 9-4 |
| Main Bearing Installation Tool | 9-4 |

FLYWHEEL BALANCING KITS

THE S&S® MASTER FLYWHEEL BALANCING KIT

| Description | Part # | MSRP |
|---|----------------|----------|
| Designed to allow the average shop to rebalance stock and S&S flywheels accurately and quickly. Whether doing a stock rebuild or a performance upgrade using aftermarket parts, flywheel rebalancing is a desirable step in the engine building process. A complete set of detailed instructions is furnished with each kit. For flywheels with tapered crankpins only. | 53-0027 | \$988.95 |

Replacement Parts

| | | |
|--|-----------------|----------|
| 1 Balance, Triple Beam Platform, w/Weights (2610 grams\maximum) (Includes weights, part #53-0021) (each) | 53-0011A | \$409.95 |
| 2. Replacement balance weight set, (2-500g 1-1000g) | 53-0021 | \$84.95 |
| 3. Balance shaft, 1936-'71 OHV BT and 1957-'71 XL | 53-0090 | \$48.95 |
| 4. Balance shaft nut (each) | 53-0092 | \$11.05 |
| 5. Balance stand (each) | 53-0088 | \$94.95 |
| 6. Rod support stand (each) | 53-0089 | \$44.95 |
| 7. Taper adapter, 1972-Early '81 BT (each) | 53-0086 | \$14.40 |
| 8. Taper adapter, Late 1981-'85 BT and S&S BL, SE, SL style (each) | 53-0087 | \$14.95 |
| 9. Shaft adapter, 1977-up XL driveside (screws on) (each) | 53-0093 | \$99.95 |
| 10. Shaft adapter, 1977-up XL camside (screws on) (each) | 53-0095 | \$88.95 |
| 11. Shaft adapter, 1955-'99 BT driveside (screws on) (each) | 53-0091 | \$93.95 |
| 12. Shaft adapter, 1958-'92 BT camside (LH, screws on) (each) | 53-0101 | \$83.95 |
| 13. Shaft adapter, 1993-'99 BT camside (RH, screws on) (each) | 53-0102 | \$88.95 |
| 14. Shaft adapter, counterweight (each) | 53-0099 | \$83.95 |
| 15. Collar spacer, 1970-'99 BT (each) | 53-0097 | \$19.95 |
| 16. Collar spacer, 1986-'90 driveside for XL - .280" (each) | 53-0098 | \$9.95 |
| 17. Collar spacer, 1991-up driveside for XL - .860" (each) | 53-0085 | \$7.20 |
| 18. Bob weight assembly, 1000 gram (each) | 53-0094 | \$81.95 |

Repair parts for 53-0094

| | | | |
|--|------|----------------|---------|
| Screw SHC, 1/2"-13 x 3/4" | Each | 50-0200 | \$1.65 |
| Screw SHC, 1/2"-13 x 1 1/4" | Each | 50-0201 | \$1.65 |
| 19. Shims | | | |
| 2.7 gram | Each | 53-0110 | \$1.75 |
| 5.4 gram | Each | 53-0105 | \$3.20 |
| 8.1 gram (H-D®853A) | | 53-0115 | \$1.10 |
| 10.8 gram | | 53-0120 | \$2.15 |
| 13.4 gram | Each | 53-0125 | \$1.75 |
| 50 gram | | 53-0150 | \$4.25 |
| 100 gram (H-D®25566-06) | | 53-0100 | \$0.95 |
| 20. Shim Kit | | | |
| Includes: Shims (2 each) 2.7, 5.4, 8.1, 10.8, and 13.4 grams & Shims (1 each) 50 grams and 100 grams | | 53-0111 | \$44.95 |

NOTE

These balancing kits will not work with Harley-Davidson® Twin Cam 88® engines, 2000-up Sportster models, or any flywheel assemblies which use pressed-in crankpins.

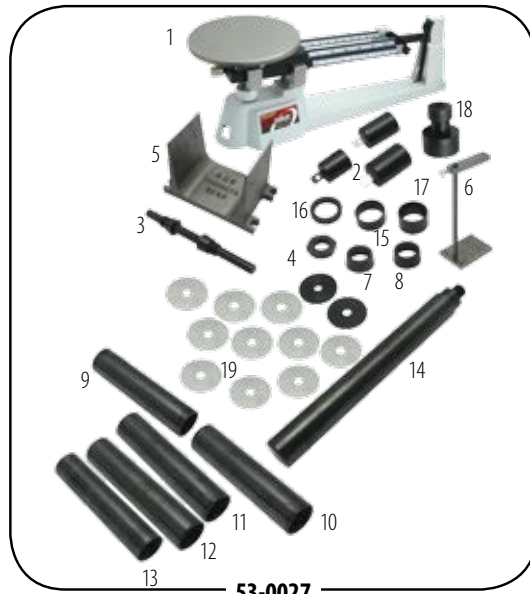

53-0027

S&S® FLYWHEEL BALANCE KITS

Master Balance Kit Without Balance Scale

| | | |
|--|----------------|----------|
| Includes all parts in #53-0027, except balance & platform scales | 53-0028 | \$749.95 |
|--|----------------|----------|

Triple Beam Platform Balance Scale

| | | |
|--------------------------------------|----------------|----------|
| (2610 grams\maximum) without weights | 53-0011 | \$347.95 |
|--------------------------------------|----------------|----------|

Flywheel Balance Kit For 5-Piece Cranks

| | | |
|-------------------|----------------|----------|
| For 5-Piece Crank | 53-0012 | \$324.95 |
|-------------------|----------------|----------|

Includes:

| | | |
|---|----------------|---------|
| 3. Balance shaft | 53-0090 | \$48.95 |
| 4. Balance shaft nut | 53-0092 | \$11.05 |
| 5. Balance stand | 53-0088 | \$94.95 |
| 6. Rod support stand | 53-0089 | \$44.95 |
| 7. Taper adapter | 53-0086 | \$14.40 |
| 8. Taper adapter | 53-0087 | \$14.95 |
| 18. Bob weight 1000 gram | 53-0094 | \$81.95 |
| 19. Shims (See previous page for individual part numbers) | | |

Flywheel Balance Kit For 3-Piece Cranks

| | | |
|---|----------------|----------|
| For Harley-Davidson® Evolution® and Sportster® Models | 53-0015 | \$521.95 |
|---|----------------|----------|

Includes:

| | | |
|--|----------------|---------|
| 9. Driveside adapter sleeve for 1977-up Sportster | 53-0093 | \$99.95 |
| 10. Camside adapter sleeve for 1977-up Sportster | 53-0095 | \$88.95 |
| 11. Driveside adapter sleeve for 1955-'99 Big Twin | 53-0091 | \$93.95 |
| 12. Camside adapter for 1958-'92 Big Twin | 53-0101 | \$83.95 |
| 13. Camside adapter for 1993-'99 Big Twin | 53-0102 | \$88.95 |
| 14. Shaft counterweight | 53-0099 | \$83.95 |
| 15. Collar spacer for 1970-'99 Big Twin | 53-0097 | \$19.95 |
| 16. Collar spacer for 1986-'90 Sportster | 53-0098 | \$9.95 |
| 17. Collar spacer for 1991-up Sportster | 53-0085 | \$7.20 |



53-0015



53-0028



53-0012

FLYWHEEL ASSEMBLY FIXTURE & TRUING SPANNER

- Includes a massive fixture to hold the flywheels, flywheel clamps and hardware to mount the flywheel to the fixture, and a spanner bar plate to be used with a length of steel pipe to fabricate a long spanner bar for truing adjustments.
- Allows the assembler to torque the mainshaft and crankpin nuts to our higher than stock torque specs. (We recommend using a torque multiplier.) Once the flywheels are assembled, the spanner bar (some assembly required) can be used to shift the flywheels in order to bring the mainshafts into true. This method is much easier, faster, and safer than hitting the flywheels with a lead or brass hammer to true the assembly.
- Works for stock and S&S flywheels for 1936-'99 big twin and 1957-'03 Sportster® models.

FLYWHEEL ASSEMBLY FIXTURE

| Description | Part # | MSRP |
|---|-----------------|----------|
| Includes clamps, plate, and hardware | 106-0552 | \$526.95 |
| REPLACEMENT PARTS | | |
| Flywheel Fixture Clamp | 106-0483 | \$64.95 |
| Spanner Bar Plate | 106-0783 | \$66.95 |
| Hardware Kit, Flywheel Fixture (includes dowel pins, nuts and screws) | 106-0782 | \$44.95 |



106-0552

SPROCKET SHAFT BEARING & SEAL INSTALLATION TOOL

FITMENT

- For Big Twin and Sportster® Models with Tapered Roller (Timken®) Sprocket Shaft Bearings

FEATURES AND BENEFITS

- Easily cuts the time it takes to install sprocket shaft bearings and seals
- Smooth operating rack and pinion system to quickly press bearings and seals into place
- Includes six adapters that converts the tool to install sprocket shaft bearings for Harley-Davidson® Sportster® models, or sprocket shaft seals for big twin and Sportster models.
- Built to stand up to daily shop use, and is covered by a two-year warranty.



53-0060

SPROCKET SHAFT BEARING AND SEAL INSTALLATION TOOL

| Description | Part # | MSRP |
|--|------------------|----------|
| For 1955-'12 Big Twin Engines (Including 1999-'12 Harley-Davidson® Twin Cam 88° engines and 1957-'12 Sportster® Models.) | 53-0060 | \$339.95 |
| Replacement Parts | | |
| Adapter, Sprocket Shaft Seal – for big twin engines | 53-0066 | \$25.95 |
| Adapter, Sprocket Shaft Seal – for Sportster Models | 53-0069 | \$49.95 |
| Replacement installer set screw | 50-0315-S | \$1.55 |



53-0066



53-0069



50-0315-S

Parts for
Twin Cam 96°/103°/110°
2007-2015

Parts for
Twin Cam 88°
1999-2006

Parts for
Evolution®
1984-1999

Parts for
Sportster & Buell®
1986-2015

Parts for
Vintage Engines
1926-1984

Parts for
X-Wedge®
2007-2015

Parts for
Indian® & Victory®
Models

Rating
Products

Tools & Shop
Supplies

Dealer Services
& Promo Items

Warranty &
Company Policy

OEM Cross Reference
Appendix & Index

BEARING PROTECTOR TOOLS FOR S&S® X-WEDGE® ENGINES

FEATURES AND BENEFITS

- Slips over the bearing surface of the X-Wedge crankshaft to prevent damage to the surface of the main bearing journal when mounting the crank on an S&S flywheel assembly fixture
- The flanged sleeve offers protection against scratches and dents
- It can also be used on the sprocket side of Victory® crankshafts
- Made of billet aluminum



Easy as 1-2-3! 106-2859 crankcase bearing protector installs in seconds, and not only protects the crankcase main bearing insert from the sharp surfaces on the sprocket shaft, but also guides the crankshaft into the bearing.

BEARING PROTECTOR TOOLS

| Description | Part # | MSRP |
|---|-----------------|---------|
| Crankshaft Main Bearing Protector | 106-2858 | \$34.95 |
| Crankcase Main Bearing Insert Protector | 106-2859 | \$41.95 |

CAM ALIGNMENT TOOLS FOR X-WEDGE® ENGINES

- Three dowel pins are used to position each of the three cam belt pulleys with alignment holes in the cam plate



CAM ALIGNMENT TOOLS

| Description | Part # | MSRP |
|---------------------------|-----------------|------------------------|
| Cam Alignment Dowels | Each | 106-0575 \$2.55 |
| | 3 pack | 106-0576 \$6.95 |
| Cam Belt Tensioner Socket | 106-0750 | \$27.95 |

MAIN BEARING INSTALLATION TOOL FOR X-WEDGE® ENGINES

- Consists of a bearing guide that holds the two plain bearing halves in position and a shouldered press tool that fits through the guide to press the new bearings into the crankcase
- The press tool is also used by itself to press old bearings out of the crankcase
- For cam and driveside bearings in X-Wedge engines
- A hydraulic or arbor press is required to install or remove bearings.



MAIN BEARING INSTALLATION TOOL FOR X-WEDGE® ENGINES

| | | |
|-------------------------------|-----------------|---------|
| Main Bearing Installation Kit | 106-0718 | \$77.95 |
|-------------------------------|-----------------|---------|

PRIMARY INNER BEARING RACE INSTALLATION TOOL

- Primary inner bearing race installation tool, with a roller thrust bearing that decreases the effort required to install a bearing race by 30%
- Attachment for the S&S Clutch Puller that allows easy removal of the primary inner bearing race
- All of these S&S tools are CNC machined from the finest 4140 tool steel and heat treated for maximum reliability and service life.



PRIMARY INNER BEARING RACE INSTALLATION TOOL

| | | |
|--------------------------------------|----------------|----------|
| Inner Primary Bearing Race Installer | 56-5145 | \$216.95 |
|--------------------------------------|----------------|----------|

Parts for Twin Cam 96/103/110™ 2007-2015
 Parts for Twin Cam 88™ 1999-2006
 Parts for Evolution™ 1984-1999
 Parts for Sportster & Buell™ 1986-2015
 Parts for Vintage Engines 1926-1984
 Parts for X-Wedge® 2007-2015
 Parts for Indian® & Victory® Models
 Racing Products
 Tools & Shop Supplies
 Dealer Services & Promo Items
 Warranty & Company Policy
 OEM Cross Reference Appendix & Index

TOP DEAD CENTER TOOL

- Easy to find the exact top dead center of any engine
- The best way to calibrate your degree wheel when dialing in cams or performing any number of checks and modifications based on the position of the crankshaft
- Available for engines with 14mm or 12mm spark plug holes.



53-0322



53-0040



53-0045



53-0002



53-0452

NOTE

Rocker covers must be removed when installing S&S compression releases. If lack of frame clearance prevents removal of rocker covers, engine must be removed from frame for compression release installation.

BORING PLATE KITS FOR CYLINDER HEADS AND CRANKCASE

- Designed to simplify and reduce the time required to prepare crankcases and cylinder heads for S&S Sidewinder® big bore kit installations
- Machined cast iron with precision ground working surfaces

BORING PLATE KIT FOR 1936-99 BIG TWIN AND 1986-'03 SPORTSTER® MODELS

| Description | Part # | MSRP |
|---|-----------------|----------|
| This boring plate kit has panhead and shovelhead head bolt patterns in one end. The other end is machined with the cylinder base patterns of 1936-'99 big twin engines, and 1986-'03 Harley-Davidson® Sportster models. Spacers are available for Evolution® engines which allow the cases to be bored without removing the cylinder studs (see below). Spacers are not included in this kit. | | |
| Kit | 53-0006 | \$361.95 |
| Boring plate (1) | N/A | |
| Screw, 7/16" -20 x 1 1/4" Sockethead Cap | 50-0172 | \$1.80 |
| 3 pack | 50-0172P | \$4.95 |

SPACERS FOR EVOLUTION CRANKCASES

Spacer part #53-0007 is required for 1986-'03 Sportster models. Spacers part #53-0007 and #53-0008 are both required for 1984-'99 big twin engines.

| | | |
|--------------|----------------|---------|
| 3 1/16" tall | 53-0007 | \$53.95 |
| 7/8" tall | 53-0008 | \$35.95 |

BORING PLATE KIT FOR CRANKCASES & CYLINDERS FOR TWIN CAM 88® ENGINES

This boring plate kit is designed for boring stock crankcases of Harley-Davidson® Twin Cam 88® engines to accept S&S Super Sidewinder® 4" and 4 1/8" bore cylinders with stock cylinder stud pattern. A spacer is included with the kit which allows the cases to be bored without removing the cylinder studs.

| | | |
|-------------------|----------------|----------|
| Kit | 53-0035 | \$317.95 |
| Boring plate | 53-0036 | \$206.95 |
| Spacer, 3/4" tall | 53-0037 | \$195.95 |

S&S® TOP DEAD CENTER TOOL

| Description | Part # | MSRP |
|-------------|----------------|---------|
| 14mm | 53-0321 | \$32.95 |
| 12mm | 53-0322 | \$32.95 |

S&S ROCKER COVER WRENCH SET

| | | |
|--|----------------|---------|
| Helpful in areas where the motorcycle frame may prevent the use of conventional tools. | 53-0040 | \$89.95 |
|--|----------------|---------|

CONNECTING ROD CHECKING PINS

These pins are used to check alignment of connecting rods and wristpin bushings with crankcase cylinder decks.

| | | |
|-------|----------------|---------|
| .791" | 53-0002 | \$37.95 |
| .927" | 53-0004 | \$37.95 |
| .990" | 53-0022 | \$37.95 |

S&S COMPRESSION RELEASE SOCKET KIT

| | | |
|---|----------------|---------|
| Allows in-frame installation of S&S compression releases and protects wiring from damage during installation. | 53-0045 | \$83.95 |
|---|----------------|---------|

MAIN JET TOOL

| | | |
|--|----------------|---------|
| For changing main jets in all S&S carburetors using #72 series jets. | 53-0452 | \$16.60 |
|--|----------------|---------|



53-0006



53-0007



53-0008



VISIT US **VSSCYCLE.COM**

Parts for
Twin Cam 96 / '03 / '10
2007-2015

Parts for
Twin Cam 88
1999-2006

Parts for
Evolution
1984-1999

Parts for
Sportster & Buell
1986-2015

Parts for
Vintage Engines
1926-1984

Parts for
X-Wedge
2007-2015

Parts for
Indian & Victory®
Models

Racing
Products

Tools & Shop
Supplies

Dealer Services
& Promo Items

Warranty &
Company Policy

OEM Cross Reference
Appendix & Index

CYLINDER TORQUE PLATE KITS

FITMENT

- S&S 4 $\frac{1}{8}$ " bore
- 4" bore 1999-up big twin
- 3 $\frac{5}{8}$ " 1984-'99 big twin
- Harley-Davidson® Sportster® models in 3 $\frac{5}{8}$ " and 4" bore
- S&S X-Wedge® 4 $\frac{1}{8}$ " bore and 4 $\frac{1}{4}$ " bore*

FEATURES AND BENEFITS

- S&S torque plates can be used in conjunction with an S&S boring fixture and a conventional boring bar, and they can be readily adapted to a Sunnen® type honing machine.

KIT CONTENTS

- Head end plate
- Base end plate
- Four long grade 8 socket head cap screws (holds the assembly together and supplies the pressure)
- Stop arm (keeps the cylinder and plates from turning while honing)

CYLINDER TORQUE PLATE REPLACEMENT PARTS

(See chart for specific part numbers.)

1. Base end torque plate
2. Head end torque plate
3. Stop arm
4. Torque bolts
5. Vise tab
6. Tab bolt



*These torque plates are required to bore or hone X-Wedge cylinders. They have the X-Wedge five bolt pattern and are available for 4 $\frac{1}{8}$ " bore and 4 $\frac{1}{4}$ " bore cylinders.

S&S® CYLINDER TORQUE PLATE KITS AND REPLACEMENT PARTS

| Bore Size | Case Bolt Pattern | Kit Part No. | Head End Plate | Base End Plate | Stop Arm | Bolt 3/8"-24 x 6" | Bolt 7/16"-20 x 6" | Bolt 7/16"-20 x 7" | Vise Tab | Tab Bolt 5/16"-18 x 1" |
|--|-------------------------------|--------------|----------------|----------------|----------|-------------------|--------------------|--------------------|----------|------------------------|
| 4 $\frac{1}{8}$ " - 4 $\frac{1}{4}$ " | S&S® X-Wedge® | 106-0836 | 106-0837 | 106-0835 | 53-0014 | 106-0840 | — | — | 53-0034 | 50-0108 |
| 4 $\frac{3}{8}$ " - 4 $\frac{7}{16}$ " | S&S 4 $\frac{3}{8}$ " Pattern | 53-0055 | 53-0056 | 53-0057 | 53-0014 | — | — | 50-0192 | 53-0034 | 50-0108 |
| 4 $\frac{1}{8}$ " | Stock 1999-up Big Twin | 53-0054 | 106-3190 | 106-3191 | 53-0014 | — | — | 50-0192 | 53-0034 | 50-0108 |
| 4 $\frac{1}{8}$ " | S&S 4 $\frac{1}{8}$ " Pattern | 53-0051 | 53-0052 | 53-0053 | 53-0014 | — | 50-0191 | — | 53-0034 | 50-0108 |
| 3.927"-4" | Stock 1999-up Big Twin | 53-0048 | 53-0049 | 53-0050 | 53-0014 | — | — | 50-0192 | 53-0034 | 50-0108 |
| 4" | S&S 4" Pattern | 53-0030 | 53-0031 | 53-0032 | 53-0014 | — | 50-0191 | 50-0192 | 53-0034 | 50-0108 |
| 3 $\frac{5}{8}$ " | 1984-'99 Big Twin | 53-0016 | 53-0017 | 53-0018 | 53-0014 | — | — | 50-0192 | 53-0034 | 50-0108 |
| 3 $\frac{5}{8}$ " | 1984-'03 Sportster® | 53-0016 | 53-0017 | 53-0018 | 53-0014 | — | — | 50-0192 | 53-0034 | 50-0108 |

S&S Cylinder torque plate kits are intended for aluminum cylinders including 1984-'99 Harley-Davidson® Evolution® big twin engines, 1986-'03 Sportster models, and 1999-up Twin Cam 88® engines.

S&S® CYLINDER TORQUE PLATE KITS

| Bore Size | Case Bolt Pattern | Part # | MSRP |
|--|-------------------------------|----------|----------|
| 4 $\frac{1}{8}$ " - 4 $\frac{1}{4}$ " | S&S® X-Wedge® | 106-0836 | \$423.95 |
| 4 $\frac{3}{8}$ " - 4 $\frac{7}{16}$ " | S&S 4 $\frac{3}{8}$ " Pattern | 53-0055 | \$439.95 |
| 4 $\frac{1}{8}$ " | Stock 1999-up Big Twin | 53-0054 | \$454.95 |
| 4 $\frac{1}{8}$ " | S&S 4 $\frac{1}{8}$ " Pattern | 53-0051 | \$439.95 |
| 3.927"-4" | Stock 1999-up Big Twin | 53-0048 | \$439.95 |
| 4" | S&S 4" Pattern | 53-0030 | \$439.95 |
| 3 $\frac{5}{8}$ " | 1984-'99 Big Twin | 53-0016 | \$401.95 |
| 3 $\frac{5}{8}$ " | 1984-'03 Sportster® | 53-0016 | \$401.95 |

S&S Cylinder torque plate kits are intended for aluminum cylinders including 1984-'99 Harley-Davidson® Evolution® big twin engines, 1986-'03 Sportster models, and 1999-up big twin engines.

Parts for Twin Cam 96 / 103 / 110 2007-2015
 Parts for Twin Cam 88 1999-2006
 Parts for Evolution® 1984-1999
 Parts for Sportster & Buell 1986-2015
 Parts for Vintage Engines 1926-1984
 Parts for X-Wedge® 2007-2015
 Parts for Indian® & Victory® Models
 Racing Products
 Tools & Shop Supplies
 Dealer Services & Promo Items
 Warranty & Company Policy
 OEM Cross Reference Appendix & Index

HEAD END PLATE

| Bore Size | Case Bolt Pattern | Part # | MSRP |
|-----------|------------------------|-----------------|----------|
| 4¼" | S&S® X-Wedge® | 106-0837 | \$208.95 |
| 4¾" | S&S 4¾" Pattern | 53-0056 | \$217.95 |
| 4½" | Stock 1999-up Big Twin | 106-3190 | \$207.95 |
| 4½" | S&S 4½" Pattern | 53-0052 | \$208.95 |
| 4" | Stock 1999-up Big Twin | 53-0049 | \$208.95 |
| 4" | S&S 4" Pattern | 53-0031 | \$208.95 |
| 3¾" | 1984-'99 Big Twin | 53-0017 | \$208.95 |
| 3¾" | 1984-'03 Sportster® | 53-0017 | \$208.95 |

BASE END PLATE

| Bore Size | Case Bolt Pattern | Part # | MSRP |
|-----------|------------------------|-----------------|----------|
| 4¼" | S&S® X-Wedge® | 106-0835 | \$208.95 |
| 4¾" | S&S 4¾" Pattern | 53-0057 | \$210.95 |
| 4½" | Stock 1999-up Big Twin | 106-3191 | \$207.95 |
| 4½" | S&S 4½" Pattern | 53-0053 | \$208.95 |
| 4" | Stock 1999-up Big Twin | 53-0050 | \$208.95 |
| 4" | S&S 4" Pattern | 53-0032 | \$208.95 |
| 3¾" | 1984-'99 Big Twin | 53-0018 | \$208.95 |
| 3¾" | 1984-'03 Sportster® | 53-0018 | \$208.95 |

STOP ARM

| Bore Size | Case Bolt Pattern | Part # | MSRP |
|-----------|-------------------|----------------|---------|
| All | All | 53-0014 | \$39.95 |

BOLT ¾"-24 X 6"

| Bore Size | Bore Size | Part # | MSRSP |
|-----------|---------------|-----------------|--------|
| 4¼" | S&S® X-Wedge® | 106-0840 | \$5.50 |

BOLT 7/16"-20 X 6"

| Bore Size | Case Bolt Pattern | Part # | MSRP |
|-----------|-------------------|--------|-------------------------|
| 4½" | S&S® 4½" Pattern | Each | 50-0191 \$13.35 |
| | | 4 pack | 50-0191P \$48.60 |
| 4" | S&S 4" Pattern | Each | 50-0191 \$13.35 |
| | | 4 pack | 50-0191P \$48.60 |

BOLT 7/16"-20 X 7"

| Bore Size | Case Bolt Pattern | Part # | MSRP |
|-----------|------------------------|--------|-------------------------|
| 4¾" | S&S 4¾" Pattern | Each | 50-0192 \$17.65 |
| | | 4 pack | 50-0192P \$64.20 |
| 4½" | Stock 1999-up Big Twin | Each | 50-0192 \$17.65 |
| | | 4 pack | 50-0192P \$64.20 |
| 4" | Stock 1999-up Big Twin | Each | 50-0192 \$17.65 |
| | | 4 pack | 50-0192P \$64.20 |
| 4" | S&S 4" Pattern | Each | 50-0192 \$17.65 |
| | | 4 pack | 50-0192P \$64.20 |
| 3¾" | 1984-'99 Big Twin | Each | 50-0192 \$17.65 |
| | | 4 pack | 50-0192P \$64.20 |
| 3¾" | 1984-'03 Sportster® | Each | 50-0192 \$17.65 |
| | | 4 pack | 50-0192P \$64.20 |

WISE TAB

| Bore Size | Case Bolt Pattern | Part # | MSRP |
|-----------|-------------------|----------------|---------|
| All | All | 53-0034 | \$22.95 |

TAB BOLT 5/16"-18 X 1"

| Bore | Case Bolt Pattern | Part # | MSRP |
|------|-------------------|---------------------|--------|
| All | All (H-D®3987) | Each 50-0108 | \$1.00 |

DEGREE WHEEL KIT

- Multipurpose S&S® degree wheel can be used to do ignition timing, crankcase breather timing, cam degreeding, or you name it
- Designed to fit the sprocket shaft of any big twin or Harley-Davidson® Sportster® model simply by using the correct adapter provided
- Each kit also comes with a pointer which is held in place with the center crankcase bolt



53-0020

S&S DEGREE WHEEL KIT

| Description | Part # | MSRP |
|--|----------------|---------|
| Kit | 53-0020 | \$90.95 |
| 1. Adapter for Sportster® models (1 Each) | 53-0023 | \$9.95 |
| 2. Adapter for big twin (1 Each) | 53-0024 | \$9.35 |
| 3. Pointer (1 Each) | 53-0025 | \$5.50 |
| 4. Degree wheel and main adapter assembly (1 Each) | 53-0026 | \$53.95 |

CRANKPIN NUT CLEARANCING GAUGES

- Designed to simplify and eliminate clearancing problems that may arise when installing stroker flywheels in stock big twin crankcases
- By painting the bosses to be clearanced and then placing the appropriate gauge on the main bearing race, the crankcases can be marked with a scribe in the proper hole for the stroke and style connecting rod crankpin nuts to be used—*quickly and precisely.*



53-0005

S&S® CRANKPIN NUT CLEARANCING GAUGES

| Description | Part # | MSRP |
|-------------------------|---------|---------|
| 1958-'99 Big Twin Gauge | 53-0005 | \$23.95 |

ANTI-ROTATION BRACKET



50-9870

S&S® ANTI-ROTATION BRACKET

| Description | Part # | MSRP |
|--|---------|---------|
| This handy bracket slides over the sprocket shaft splines of big twin engines and bolts to one of the primary bolt holes of the crankcase to keep the crank from rotating. It's like an extra set of hands while installing pistons and cylinders. | 50-9870 | \$11.65 |

CRANKCASE OIL PASSAGE DRILLING JIG

Drill Jig Is Used To Drill...

- Primary chain oil supply passage from the breather valve gear cavity to the back side of the oil pump body on late generator and early alternator crankcases.
- Pressure relief passage from behind the main oil pressure valve to the gear cavity on alternator crankcases.
- Crankshaft and main bearings supply passage on generator crankcases.
- Crankshaft and main bearings supply passage on early alternator crankcases.

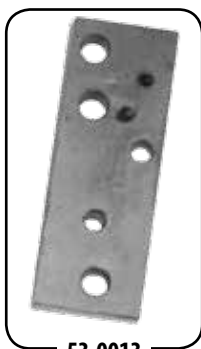

53-0013

S&S CRANKCASE OIL PASSAGE DRILLING JIG

| Description | Part # | MSRP |
|---|---------|---------|
| The S&S crankcase oil passage drilling jig is used to perform crankcase drilling modifications when installing an S&S oil pump assembly on early big twin crankcases. Made of hardened steel for durability, this fixture enables the builder to do four modifications. | 53-0013 | \$43.95 |

TAPPET BLOCK ALIGNMENT TOOL

- Aligns tappet block so the tappet rollers run straight on the cam lobe to prevent camshaft wear



530-0014

S&S® TAPPET BLOCK ALIGNMENT TOOL

| Description | Part # | MSRP |
|-------------------------------|----------|---------|
| Tool, Tappet Guide, Alignment | 530-0014 | \$14.95 |

Parts for Twin Cam 96/103/110 2007-2015
 Parts for Twin Cam 88 1999-2006
 Parts for Evolution 1984-1999
 Parts for Sportster & Buell 1986-2015
 Parts for Vintage Engines 1926-1984
 Parts for X-Wedge 2007-2015
 Parts for Indian & Victory Models
 Racing Products
 Tools & Shop Supplies
 Dealer Services & Promo Items
 Warranty & Company Policy
 OEM Cross Reference Appendix & Index

S&S® LUBRICANTS

- Complete drive train protection – Engine, transmission, and primary
- Superior Lubrication – Exceeds S&S® and Harley-Davidson® warranty requirements
- Reduced wear – Enhanced levels of zinc and phosphorous for longer engine life and high flash additives are safe for catalytic converters!
- Multiple grades and formulations – Petroleum or full synthetic
- Easy pour “long neck” bottle – No funnel needed
- Made in the USA!



S&S ENGINE OIL

| Blend | Case of 12 / 1-Qt bottles | MSRP |
|----------------------|---------------------------|----------|
| 20w50 Full Synthetic | 310-0285 | \$155.40 |
| 20w50 Petroleum | 310-0287 | \$95.40 |
| 25W60 Petroleum | 310-0289 | \$95.40 |

S&S TRANSMISSION OIL

| Blend | Case of 12 / 1-Qt bottles | MSRP |
|-----------------------|---------------------------|----------|
| 75W140 Full Synthetic | 310-0292 | \$227.40 |
| 85W140 Petroleum | 310-0291 | \$119.40 |

S&S PRIMARY OIL

| Blend | Case of 12 / 1-Qt bottles | MSRP |
|--------------|---------------------------|---------|
| Extreme Duty | 310-0290 | \$95.40 |

QUICK OIL CHANGE KIT

KIT CONTENTS

- Four quarts of either S&S Heavy Duty 20w50 Petroleum, or Premium Full Synthetic motor oil
- S&S oil filter with chrome finish



S&S QUICK OIL CHANGE KITS

| Fitment | S&S 20w50 Premium Synthetic | | S&S 20w50 Heavy Duty | |
|--|-----------------------------|---------|----------------------|---------|
| 1984-'99 BT, 1986-'14 XL and 1991-'02 Buell® | 310-0297 | \$64.95 | 310-0293 | \$44.95 |
| 1999-'14* BT and all X-Wedge®* | 310-0298 | \$64.95 | 310-0294 | \$44.95 |
| 1958-'82 Big Twins and 1953-'78 K and Sportster® Models With In-Tank Filters** | 310-0301 | \$59.95 | 310-0299 | \$39.95 |

*Contains an anti-drain back valve

**Includes Perf-form® HD-1 drop in filter

OIL FILTERS

FEATURES AND BENEFITS

- Captures smaller particles than stock filters
- Low restriction to oil flow
- Direct bypass – bypass oil does not pass over dirty filter media
- Smaller diameter for easier installation
- Black or chrome finish



S&S® OIL FILTERS

| Year Application | Micron Rating | QTY | Chrome | MSRP | Black | MSRP |
|--|---------------|---------|---------------------------------|----------|---------------------------------|----------|
| 1984-'99 Evolution®, 1986-'14 XL and 1991-'02 Buell® | 30µ | each | 31-4102 (H-D®63796-77A) | \$14.40 | 31-4101 (H-D®63805-80A) | \$11.65 |
| | | 12 pack | 310-0240 (H-D®63796-77A) | \$157.95 | 310-0239 (H-D®63805-80A) | \$127.95 |
| 1999-'14* Twin Cam 88®/96™/103™ and all X-Wedge® | 10µ | each | 31-4104 | \$14.40 | 31-4103 | \$11.65 |
| | | 12 pack | 310-0242 | \$157.95 | 310-0241 | \$127.95 |

*Contains an anti-drain back valve



PERFORM HD-1 OIL FILTER

| Description | Part # | MSRP |
|--|-----------------|--------|
| Each (H-D®63799-65A, 63840-53, 63826-53) | 310-0284 | \$8.99 |

CHAMPION® SPARK PLUGS



55-1322

CHAMPION® SPARK PLUGS

| Application | Size | QTY | Part No. | MSRP |
|---|--------------------------------------|--------|-------------------------------|---------|
| Twin Cam 88®/96™/103™, Sportster®, X-Wedge® & S&S 4 1/8" bore engines | 12mm Long Reach Champion® #RA8HC | each | 55-1320 (H-D®32362-04) | \$6.30 |
| | | 2 pack | 55-1322 (H-D®32362-04) | \$11.45 |
| Evolution®, Vintage Models (SH-Series, Iron XL, KN-Series, P-Series) & S&S 3 3/8" & 4" bore engines | 14mm Long Reach Champion® #RN12YC | each | 55-1321 (H-D®32342-04) | \$4.85 |
| | | 2 pack | 55-1323 (H-D®32342-04) | \$8.85 |

Parts for
Twin Cam 96™/103™/110™
2007-2015

Parts for
Twin Cam 88®
1999-2006

Parts for
Evolution®
1984-1999

Parts for
Sportster® & Buell®
1986-2015

Parts for
Vintage Engines
1926-1984

Parts for
X-Wedge®
2007-2015

Parts for
Indian® & Victory®
Models

Rating
Products

Tools & Shop
Supplies

Dealer Services
& Promo Items

Warranty &
Company Policy

OEM Cross Reference
Appendix & Index

JETS & CARB REBUILD KITS FOR S&S SUPER E & G CARBURETORS

For those who need to rejet their carburetor because of engine modifications, exhaust modifications, or changes in altitude, we have extra jet kits available which are designed to cover most jetting situations.

DEALER JET KITS

| Description | Part No. | MSRP |
|--|----------------|----------|
| S&S Carb Parts Kit (Contains needed parts to maintain S&S Super E and G carburetors) | 11-3103 | \$340.95 |
| S&S Jet Kit (Includes 3 each of all intermediate jets and 5 each of all main jets, plus a main jet tool) | 11-3102 | \$317.95 |

JET PACKS

| Description | Part No. | MSRP |
|---|----------------|---------|
| Low Range Jet Pack – For jetting most stock and moderate performance engines. <i>Includes one each intermediate jets (.025", .0265", .028", .0295") one each main jets (.062", .064", .066", .068", .070", .072", .074").</i> | 11-7270 | \$46.95 |
| High Range Jet Pack – For jetting some stock and all performance engines. <i>Includes one each intermediate jets (.0295", .031", .032", .033") and one each main jets (.072", .074", .076", .078", .080", .082", .084").</i> | 11-7271 | \$46.95 |
| Master Jet Pack – For jetting all Super B, E, and G equipped engines. <i>Includes one each intermediate jets (.025", .0265", .028", .0295", .031", .032", .033") and one each main jets (.062", .064", .066", .068", .070", .072", .074", .076", .078", .080", .082", .084").</i> | 11-7272 | \$80.95 |



11-3103



11-3102

INTERMEDIATE JETS - SERIES #94 INDIVIDUAL SELECTION

| Size | QTY | Part No. | MSRP | Size | QTY | Part No. | MSRP |
|-------|--------|----------------|---------|-------|--------|----------------|---------|
| .025 | each | 11-0250 | \$8.80 | .032 | each | 11-0320 | \$8.80 |
| | 3 pack | 11-7107 | \$23.95 | | 3 pack | 11-7112 | \$23.95 |
| .0265 | each | 11-0265 | \$8.80 | .033 | each | 11-0330 | \$8.80 |
| | 3 pack | 11-7108 | \$23.95 | | 3 pack | 11-7113 | \$23.95 |
| .028 | each | 11-0280 | \$8.80 | .036 | each | 11-0360 | \$8.80 |
| | 3 pack | 11-7109 | \$23.95 | | 3 pack | 11-7114 | \$23.95 |
| .0295 | each | 11-0295 | \$8.80 | .040 | each | 11-0400 | \$8.80 |
| | 3 pack | 11-7110 | \$23.95 | | 3 pack | 11-7115 | \$23.95 |
| .031 | each | 11-0310 | \$8.80 | Blank | each | 11-0000 | \$8.80 |
| | 3 pack | 11-7111 | \$23.95 | | 3 pack | 11-7116 | \$23.95 |



11-7272



106-3517

Early Series #94 gas jets were stamped with single digit numbers. Conversions for these numbers are:

| | | | |
|--------|-------|--------|-------|
| 1..... | .025" | 4..... | .033" |
| 2..... | .028" | 5..... | .036" |
| 3..... | .031" | 6..... | .040" |

NOTES

No returns or exchanges on jets.

Refer to Section 8: Racing for the S&S fuel and turbo carburetors.

Parts for Twin Cam 96 / 103 / 110 2007-2015
 Parts for Twin Cam 88 1999-2006
 Parts for Evolution 1984-1999
 Parts for Sportster & Buell 1986-2015
 Parts for Vintage Engines 1926-1984
 Parts for X-Wedge 2007-2015
 Parts for Indian & Victory Models
 Racing Products
 Tools & Shop Supplies
 Dealer Services & Promo Items
 Warranty & Company Policy
 OEM Cross Reference Appendix & Index

MAIN JETS - SERIES #72 INDIVIDUAL SIZE SELECTION

| Size | QTY | Part No. | MSRP | Size | QTY | Part No. | MSRP |
|------|--------|----------|---------|-------|--------|-----------|---------|
| .040 | each | 11-4040 | \$7.70 | .080 | each | 11-4080 | \$7.70 |
| | 5 pack | 11-7220 | \$34.95 | | 5 pack | 11-7240 | \$34.95 |
| .042 | each | 11-4042 | \$7.70 | .082 | each | 11-4082 | \$7.70 |
| | 5 pack | 11-7221 | \$34.95 | | 5 pack | 11-7241 | \$34.95 |
| .044 | each | 11-4044 | \$7.70 | .084 | each | 11-4084 | \$7.70 |
| | 5 pack | 11-7222 | \$34.95 | | 5 pack | 11-7242 | \$34.95 |
| .046 | each | 11-4046 | \$7.70 | .086 | each | 11-4086 | \$7.70 |
| | 5 pack | 11-7223 | \$34.95 | | 5 pack | 11-7243 | \$34.95 |
| .048 | each | 11-4048 | \$7.70 | .088 | each | 11-4088 | \$7.70 |
| | 5 pack | 11-7224 | \$34.95 | | 5 pack | 11-7244 | \$34.95 |
| .050 | each | 11-4050 | \$7.70 | .090 | each | 11-4090 | \$7.70 |
| | 5 pack | 11-7225 | \$34.95 | | 5 pack | 11-7245 | \$34.95 |
| .052 | each | 11-4052 | \$7.70 | .092 | each | 11-4092 | \$7.70 |
| | 5 pack | 11-7226 | \$34.95 | | 5 pack | 11-7246 | \$34.95 |
| .054 | each | 11-4054 | \$7.70 | .094 | each | 11-4094 | \$7.70 |
| | 5 pack | 11-7227 | \$34.95 | | 5 pack | 11-7247 | \$34.95 |
| .056 | each | 11-4056 | \$7.70 | .096 | each | 11-4096 | \$7.70 |
| | 5 pack | 11-7228 | \$34.95 | | 5 pack | 11-7248 | \$34.95 |
| .058 | each | 11-4058 | \$7.70 | .098 | each | 11-4098 | \$7.70 |
| | 5 pack | 11-7229 | \$34.95 | | 5 pack | 11-7249 | \$34.95 |
| .060 | each | 11-4060 | \$7.70 | .100 | each | 11-4100 | \$7.70 |
| | 5 pack | 11-7230 | \$34.95 | | 5 pack | 11-7250 | \$34.95 |
| .062 | each | 11-4062 | \$7.70 | .102 | each | 11-4102 | \$7.70 |
| | 5 pack | 11-7231 | \$34.95 | | 5 pack | 11-7251 | \$34.95 |
| .064 | each | 11-4064 | \$7.70 | .104 | each | 11-4104 | \$7.70 |
| | 5 pack | 11-7232 | \$34.95 | | 5 pack | 11-7252 | \$34.95 |
| .066 | each | 11-4066 | \$7.70 | .106 | each | 11-4106 | \$7.70 |
| | 5 pack | 11-7233 | \$34.95 | | 5 pack | 11-7253 | \$34.95 |
| .068 | each | 11-4068 | \$7.70 | .108 | each | 11-4108-S | \$7.70 |
| | 5 pack | 11-7234 | \$34.95 | | 5 pack | 11-7254 | \$34.95 |
| .070 | each | 11-4070 | \$7.70 | .110 | each | 11-4110 | \$7.70 |
| | 5 pack | 11-7235 | \$34.95 | | 5 pack | 11-7255 | \$34.95 |
| .072 | each | 11-4072 | \$7.70 | .115 | each | 11-4115 | \$7.70 |
| | 5 pack | 11-7236 | \$34.95 | | 5 pack | 11-7256 | \$34.95 |
| .074 | each | 11-4074 | \$7.70 | .120 | each | 11-4120 | \$7.70 |
| | 5 pack | 11-7237 | \$34.95 | | 5 pack | 11-7257 | \$34.95 |
| .076 | each | 11-4076 | \$7.70 | Blank | each | 11-4040 | \$7.70 |
| | 5 pack | 11-7238 | \$34.95 | | 5 pack | 11-7258 | \$34.95 |
| .078 | each | 11-4078 | \$7.70 | | | | |
| | 5 pack | 11-7239 | \$34.95 | | | | |

MAIN JET AIR BLEED KIT (One Jet Each Size)

| Sizes | Part No. | MSRP |
|---------------|----------|---------|
| .042" - .060" | 106-3517 | \$64.95 |
| .084" - .120" | 106-3518 | \$48.95 |

S&S® Carburetor Rebuild Kits

To insure that you continue to get the utmost in performance from your S&S carburetor, we have put together a series of rebuild kits that are designed to provide the proper parts to return a worn carburetor to top shape. We have assembled different types of kits to cover the different degrees of rebuild necessary.

Master Rebuild Kits

Master rebuild kits contain a body rebuild kit, accelerator pump rebuild kit (Super E and G only), all new fasteners, springs, idle mixture screw, seat, and needle assembly. Everything needed to completely rebuild one carburetor.

MASTER REBUILD KIT

| Description | Part No. | MSRP |
|-------------|----------|---------|
| Super E | 11-2923 | \$80.95 |
| Super G | 11-2924 | \$80.95 |



11-2923

Body Rebuild Kits

Body rebuild kits for Super E and G carbs also contain throttle shaft nuts, nylon washers, accelerator pump o-ring, and accelerator pump boot. Body rebuild kits for Super E and G carbs do not contain throttle shaft bushings since these carbs have stainless steel throttle shaft bushings already installed.

BODY REBUILD KIT

| Description | Part No. | MSRP |
|-------------|----------|---------|
| Super E | 11-2906 | \$40.95 |
| Super G | 11-2907 | \$40.95 |



11-2907

Basic Rebuild Kit

A gasket and seal kit for low mileage Super E & G carbs. Perfect to reassemble carbs taken apart for inspection and cleaning.

BASIC REBUILD KIT

| Description | Part No. | MSRP |
|-------------|----------|---------|
| Super E & G | 110-0067 | \$31.95 |



110-0067

Accelerator Pump Rebuild Kits

Accelerator pump rebuild kits contain diaphragm, diaphragm spring, check balls, check ball spring, pump pushrod, and required hardware and o-rings.

ACCELERATOR PUMP REBUILD KIT

| Description | Part No. | MSRP |
|-------------|----------|---------|
| Super E & G | 11-2918 | \$19.95 |



11-2918

Parts for
Twin Cam 96°/103°/110°
2007-2015

Parts for
Twin Cam 88°
1999-2006

Parts for
Evolution
1984-1999

Parts for
Sportster & Buell
1986-2015

Parts for
Vintage Engines
1926-1984

Parts for
X-Wedge
2007-2015

Parts for
Indian & Victory
Models

Rating
Products

Tools & Shop
Supplies

Dealer Services
& Promo Items

Warranty &
Company Policy

OEM Cross Reference
Appendix & Index

Parts for Twin Cam 96 / 103 / 110 2007-2015
 Parts for Twin Cam 88 1999-2006
 Parts for Evolution 1984-1999
 Parts for Sportster & Buell 1986-2015
 Parts for Vintage Engines 1936-1984
 Parts for X-Wedge 2007-2015
 Parts for Indian & Victory Models
 Racing Products
 Tools & Shop Supplies
 Dealer Services & Promo Items
 Warranty & Company Policy
 OEM Cross Reference Appendix & Index

TOUCH UP PAINT, LUBRICANT AND SEALANTS



106-3023



51-9001



51-9009



51-9000



51-9002



500-0143

TOUCH UP PAINT

| Description | Part # | MSRP |
|---|----------|--------|
| S&S touch up paint is included with each powdercoated S&S engine, but it's handy to have a spare! Keep one in the shop and one in your saddle bag. Sold in ½ oz. bottles with applicator cap. | | |
| Wrinkle Black ½ oz. (used prior April 2009)* | 51-9001 | \$4.40 |
| Wrinkle Black ½ oz, matte finish (used after April 2009)* | 510-0053 | \$6.95 |
| Silver ½ oz | 106-3023 | \$8.50 |

*NOTE: Wrinkle Black (51-9001) has a slightly glossy finish. Wrinkle Black (510-0053) has a matte finish with no gloss.

LUBRICANT AND SEALANTS

Use what the pros use! S&S assembles a lot of engines and customers often ask what sealants and lubricants we use. We recommend and use the following:

Torco® Engine Assembly Lube

Protect engine components during assembly and initial start up!

| | | |
|--------------|---------|--------|
| 4 oz. Bottle | 51-9000 | \$8.30 |
| 1 oz. Tube | 51-9002 | \$4.45 |

Gasgacinch® Gasket Sealer

| | | |
|-------------------|---------|--------|
| 4 oz. (118ml) Can | 51-9009 | \$7.25 |
|-------------------|---------|--------|

ThreeBond® Liquid Gasket 1194

| | | |
|--|----------|---------|
| Great for sealing crankcases! 3.5 oz. (100g) Tube | 500-0143 | \$15.40 |
|--|----------|---------|

ENGINE STANDS

- An economical way to hold an engine on the work bench, for shipping, or for display
- Constructed of heavy gauge stamped steel with "S&S" laser cut in both ends
- Bullet proof, blue powder coat finish gives the stands a professional appearance that is suitable for display and protects them from corrosion and minor abrasions



S&S® ENGINE STANDS

| Application | Part No. | MSRP |
|-------------------------------------|----------|---------|
| S&S X-Wedge® Engines | 53-0147 | \$66.95 |
| 1936-'99 Big Twin Engines | 53-0141 | \$66.95 |
| 1999-Up Unbalanced Big Twin Engines | 53-0143 | \$66.95 |
| 1999-'06 Balanced Big Twin Engines | 53-0145 | \$57.55 |